

Freefall metal detection system Vistus® with separator FL

The space-saving model



ⓘ Separator FL benefits

- For maximum space-saving: the low installation height allows for especially short complete systems

ⓘ Benefits of Vistus® technology

- Maximum detection sensitivity
- True In-Process Validation
- Compact enough to be used in even the tightest of spaces
- Easy installation and operation



The innovative Freefall Metal Detection System Vistus®, in combination with the separator FL, provides reliable, space-saving detection of metal foreign bodies in the product stream.

Perfected for maximum safety

- ⓘ The freefall metal detection system Vistus® offers maximum detection performance for the food industry. All **metal foreign bodies, including ferrous and non-ferrous metals and even non-magnetic stainless steels**, are consistently detected and separated from the production line.
- ⓘ The optional **True In-Process Validation** guarantees **authentic performance validation** – in the centre of the search coil and while the process is running.
- ⓘ **Space-saving product components** and a **reduced metal-free zone** make applications in the tightest of space possible.
- ⓘ When combined with the **space-saving** separator FL, Vistus® allows especially short complete systems to be created. By using the Vistus® RMFZ search coil, the **low installation height** can be reduced even further.

Freefall Metal Detection System Vistus® with separator FL

The separator FL is used to configure your Freefall System Vistus® for maximum space-saving. The low installation height allows especially short complete systems to be created, making the separator FL an ideal complement to the Vistus® RMFZ search coil. By choosing the specially-designed combination of search coil, pipe and optional True In-Process Validation, you can customise your metal detection system to meet your specific needs.

Control unit

Vistus® E operator terminal
Scale drawing

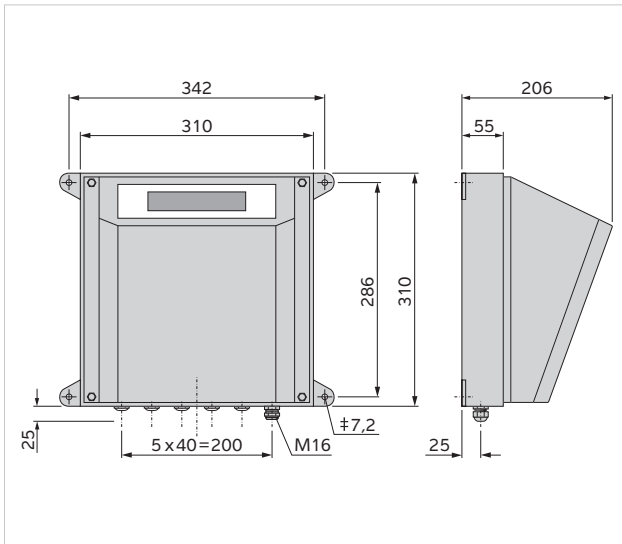

One control unit is suitable for connecting up to four search coils.

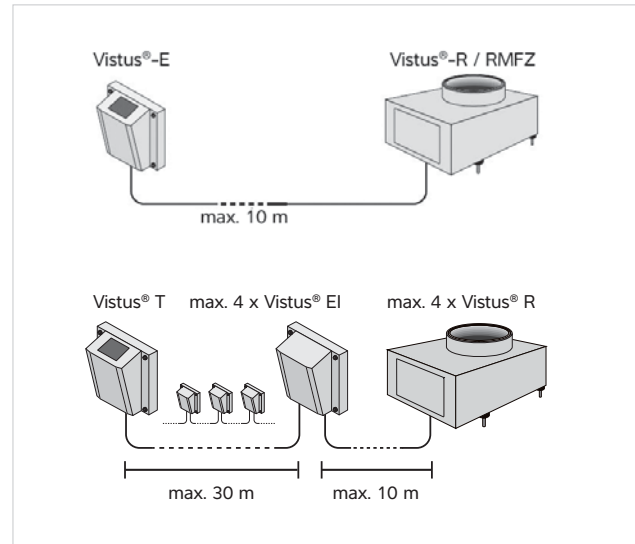

Search coil options

Vistus® R search coil
Scale drawing

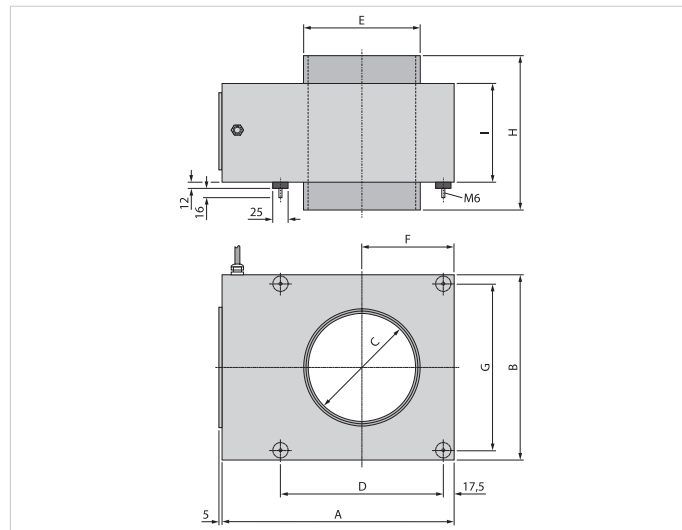

Coil dimensions

Vistus® R	A	B	C	D	E	F	G	H	I	kg
2.8	289	195	28	160	39.5	97.5	160	175	160	12
5.9	289	195	59	160	70.5	97.5	160	185	160	10.7
8.4	289	195	84	160	97.5	97.5	160	195	160	9.2
12	289	195	120	160	132.5	97.5	160	205	160	7.7
17.2	393	300	172	256	187.5	150	265	250	160	16.5
21.6	393	300	216	256	232.5	150	265	260	160	14.6
26.9	523	430	269	359	288	215	395	310	200	28
34.1	523	430	341	359	363	215	395	320	200	30

Search coil options

Vistus® RMFZ search coil
Scale drawing

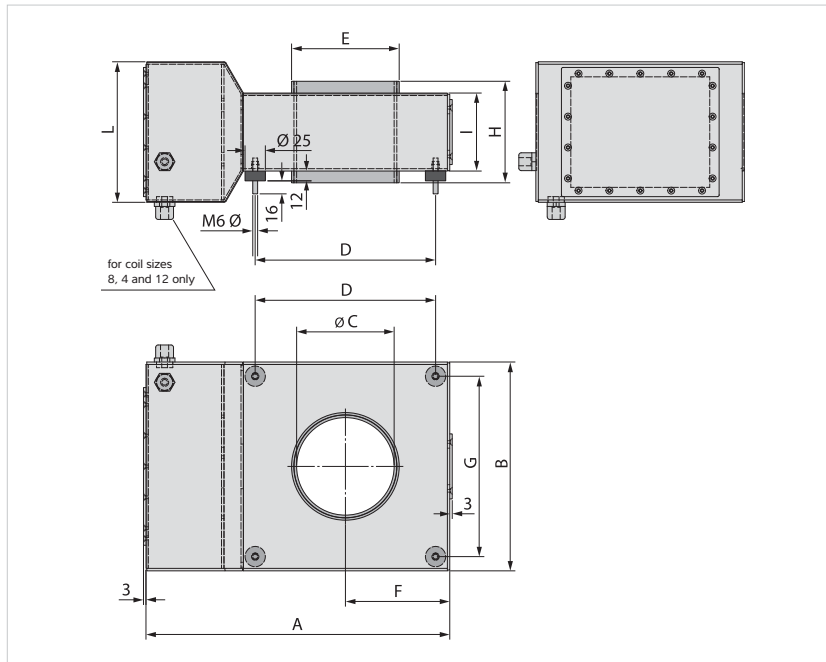

Coil dimensions

Vistus® RMFZ	A	B	C	D	E	F	G	H	I	L	kg
8.4	337	212	84	177	97.5	106	177	88	68	173	9.5
12	374	257	120	222	132.5	129	222	125	96	173	13
17.2	427	322	172	287	187.5	161	287	180	138	173	19.5
21.6	473	380	216	345	232.5	190	345	225	173	173	25
26.9	538	445	269	410	288	223	410	280	215	215	36
34.1	627	534	341	499	363	267	499	355	273	273	55

Advantages of RMFZ over Standard

If moving parts made from aluminium or stainless steel (VA 1.4301), such as the scale pans on a bagging machine, are operated in front of the Vistus® R, 0.8 times the passage height must be maintained as a metal-free zone above and below the metal detector.

Vistus® RMFZ makes it possible to reduce this metal-free zone to 0.64 times the amount, in addition to the mechanically low installation height.

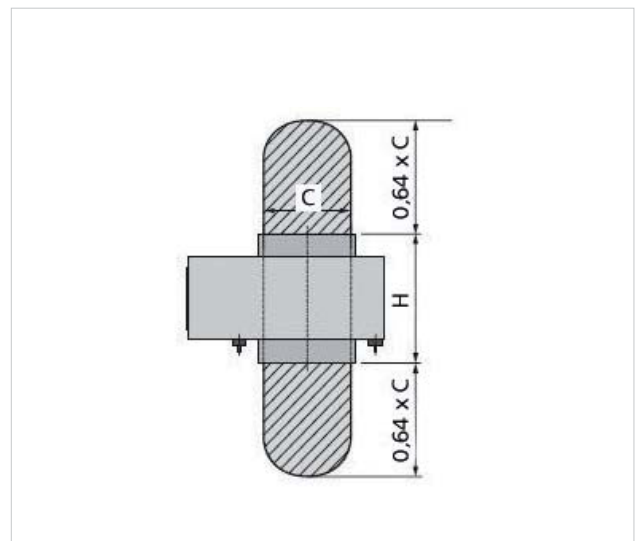
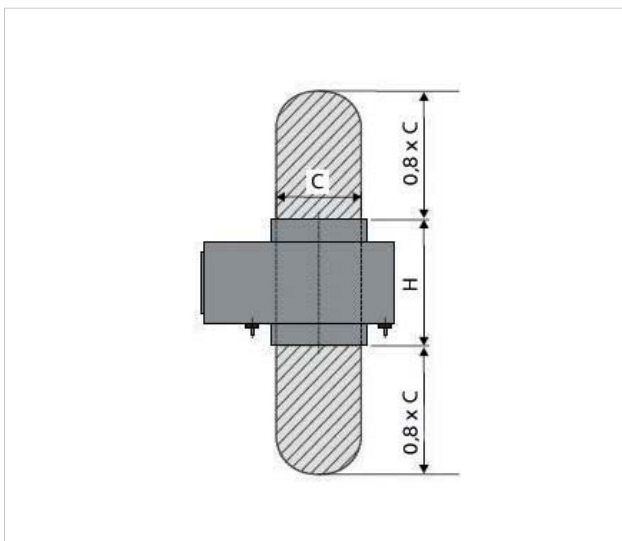

Throughputs

Different designs of the freefall metal detection system Vistus® are available.

Freefall pipe with separator			
Nominal width NW in mm, Separator	Diameter Di in mm, freefall pipe	Metal detector opening	Throughput kg/h
NW 80	Di 55.8	8.4	3,850
NW 100	Di 96.8	12	6,000
NW 150	Di 152.2	17.2	13,500
NW 200	Di 190.2	21.6	24,000
NW 250	Di 237.8	26.5	38,000
NW 300	Di 299.6	34.1	54,000

The effective throughput depends on the flow characteristics and density of the product. The values in the table refer to a density of $\rho=1000 \text{ kg/m}^3$. If the product's flow characteristics are optimal, the guide values can be exceeded by 50%. The data listed in this table, for example, describes a freefall metal detection system with a separator FL. Introducing a collecting grid reduces the amount of pipe cross-section available. Furthermore, a product build-up may occur in the collecting grid area as the product is falling through (because of, for example, turbulence), which may lead to a blockage.

For this reason, the collecting grid should only remain in the product stream for the short duration of a test using Minebea Intec test parts. A cover without a collecting tray, which enables you to seal the opening before and after the test and reduce the impact on the product flow, is included as standard.



Pipe quality options

Various materials are available for the freefall pipe of the metal detector:

PP – standard polypropylene pipe: suitable for detection of foreign bodies in products that do not generate static electricity. Universal solution for products that are not susceptible to electrical discharge. Outer graphite coating for static discharge.

ESD: meets food safety requirements thanks to health clearance as per EU regulations (nos 10/2011 and 1935/2004). The ESD pipe continually neutralises static charging.

Ceramic: for applications with product temperatures up to 150 °C (available upon request).

		Pipe material		
		PP graphite-coated	ESD	Ceramic
Product temperature $\vartheta < 70 \text{ °C}$	electrostatic charging	■	■	■
	abrasive			■
Product temperature $\vartheta > 70 \text{ °C}$	electrostatic charging			■
	abrasive			■
Illustration				

General installation instructions

Freefall metal detection systems are suitable as standard for product temperatures up to +70 °C and ambient temperatures up to +55 °C. The air cooling option may be required with higher temperatures. We are happy to help you integrate the system into your process. Our Engineering Support team will create a custom frame for installation in your production line if required. Alternatively, you can select one of the versions listed here with larger pipe cross-sections or without a separator.

- The dimensions listed in the tables apply to the 'drop heights above flange' specified in the tables, when the product has a start speed of 0 metres per second (0 m/sec)
- The total drop distance through the frefall pipe must not exceed 2.070 m for EX applications
- The following tolerances may emerge through the production process with the diameters and wall thicknesses for the ceramic frefall pipes listed in the tables

NW	80	100	150	200	250	300
Di ceramic	80	100	150	200	250	300
+/- tolerance in mm	4.5	5.5	7	9	10	11

Vistus® complete system with separator FL

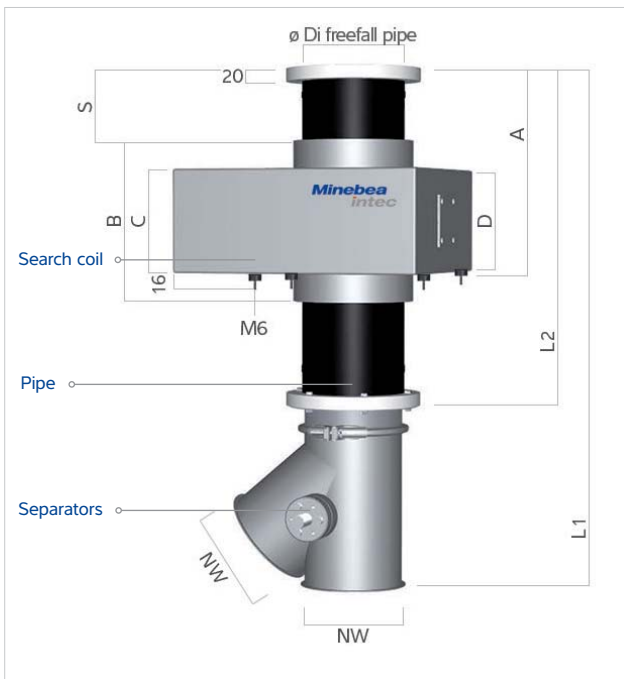

Legend	
NW	Nominal width – TCU in mm
Di frefall pipe	Diameter inside frefall pipe in mm
T	Freefall pipe wall thickness in mm
L1	Freefall pipe with separator length in mm
L2	Freefall pipe length in mm
A	Distance from flange F1 to rubber-bonded metal elements in mm
B	Wide search coil passage in feed direction in mm
C	Wide housing search coil in feed direction in mm
D	Wide housing electronics in feed direction in mm
S	Distance from flange F1 to search coil inlet in mm

The grain size of the bulk material should be > 2 mm and < 30 mm. In exceptional cases, depending on the density of the product, a larger grain may also be permissible. Smaller grain sizes can result in product loss in the separator brackets.

Standard version with reduced metal-free zone for Vistus® TCU-FL

Metal detector opening	8.4	12	17.2	21.6	26.9	34.1
-FL	8	10	15	20	25	30
NW	80	100	150	200	250	300
Di PP	55.8	96.8	152.2	190.2	237.8	299.6
Di ESD	55.8	97.4	141.8	177.2	221.6	279.2
Di ceramic	--	80	100	150	200	250
T PP	3.6	6.6	3.9	4.9	6.1	7.7
T ESD	3.6	6.3	9.1	11.4	14.2	17.9
T ceramic	--	10	10	10	10	10
L1	482	584	767	1201	1504	1801
L2	297	367	482	830	1017	1243
A	144	199	281	349	432	544
B	88	125	180	225	280	355
C	68	96	138	173	215	273
D	173	173	173	173	215	215
S	54	77	110	138	172	218

Standard version for Vistus® TCU-FL

Metal detector opening	8.4	12	17.2	21.6	26.9	34.1
-FL	8	10	15	20	25	30
NW	80	100	150	200	250	300
Di PP	55.8	96.8	152.2	190.2	237.8	299.6
Di ESD	55.8	97.4	141.8	177.2	221.6	279.2
Di ceramic	--	80	100	150	200	250
T PP	3.6	6.6	3.9	4.9	6.1	7.7
T ESD	3.6	6.3	9.1	11.4	14.2	17.9
T ceramic	--	10	10	10	10	10
L1	565	653	810	1230	1523	1801
L2	380	436	525	859	1036	1243
A	274	308	355	395	482	545
B	230	240	250	260	310	320
C	160	160	160	160	200	200
D	160	160	160	160	200	200
S	67	96	138	173	215	273

Vistus® complete system with EX category 3 separator

Special category 3 (outdoor use) version for Vistus® TCU-FL

Metal detector opening	12	17.2	21.6
-FL	10	15	20
NW	100	150	200
Di PP	90	141.8	177.2
Di ESD	97.4	141.8	177.2
Di ceramic	80	100	150
T PP	10	9.1	11.4
T ESD	6.3	9.1	11.4
T ceramic	10	10	10
L1	724	877	1296
L2	507	592	957
A	308	355	395
B	240	250	260
C	160	160	160
D	160	160	160
S	96	138	173

Special category 3 (outdoor use) version with air cooling and/or a shield for Vistus® TCU-FL

Metal detector opening	17.2	21.6
-FL	10	15
NW	100	150
Di PP	90	141.8
Di ESD	100	150
T PP	10	9.1
T ceramic	10	10
L1	763	1157
L2	546	872
A	355	395
B	250	260
C	160	160
D	160	160
S	138	173

Special category 3 (outdoor use) version with reduced metal-free zone for Vistus® TCU-FL

Metal detector opening	12	17.2	21.6
-FL	10	15	20
NW	100	150	200
Di PP	90	141.8	177.2
Di ESD	97.4	141.8	177.2
Di ceramic	80	100	150
T PP	10	9.1	11.4
T ESD	6.3	9.1	11.4
T ceramic	10	10	10
L1	650	843	1266
L2	433	558	895
A	199	281	349
B	125	180	225
C	160	160	160
D	160	160	160
S	77	110	138



Explosion protection

Vistus® complete system with separator and air cooling/shielding

Version with shielding and/or air cooling for Vistus® TCU-FL

Metal detector opening	12	17.2	21.6	26.9	34.1	34.1
-FL	8	10	15	20	25	30
NW	80	100	150	200	250	300
Di PP	55.8	96.8	152.2	190.2	237.8	299.6
Di ceramic	80	100	150	200	250	300
T PP	3.6	6.6	3.9	4.9	6.1	7.7
T ceramic	10	10	10	10	10	10
L1	617	742	1095	1348	1664	1801
L2	432	525	810	977	1177	1243
A	308	355	395	482	545	545
B	240	250	260	310	320	320
C	160	160	160	200	200	200
D	160	160	160	200	200	200
S	96	138	173	215	273	273

Version with shielding and/or air cooling with reduced metal-free zone for Vistus® TCU-FL

Metal detector opening	12	17.2	21.6	26.9	34.1	34.1
-FL	8	10	15	20	25	30
NW	80	100	150	200	250	300
Di PP	55.8	96.8	152.2	190.2	237.8	299.6
Di ceramic	80	100	150	200	250	300
T PP	3.6	6.6	3.9	4.9	6.1	7.7
T ceramic	10	10	10	10	10	10
L1	523	657	1065	1329	1664	1801
L2	338	440	780	958	1177	1243
A	199	281	349	432	544	544
B	125	180	225	280	355	355
C	96	138	173	215	273	273
D	173	173	173	215	215	215
S	77	110	138	172	218	218

Version with air cooling and/or shielding and/or a larger pipe cross-section with a reduced metal-free zone for Vistus® TCU-FL

Metal detector opening	17.2	21.6	26.9	34.1
-FL	10	15	20	25
NW	100	150	200	250
Di PP	102.2	147.6	199.4	248.2
T PP	11.4	6.2	12.8	15.9
L1	657	1040	1317	1664
L2	440	755	946	1177
A	281	349	432	544
B	180	225	280	355
C	160	160	200	200
D	160	160	200	200
S	110	138	172	218

Version with air cooling and/or shielding and/or a larger pipe cross-section for Vistus® TCU-FL

Metal detector opening	17.2	21.6	26.9	34.1
-FL	10	15	20	25
NW	100	150	200	250
Di PP	102.2	147.6	199.4	248.2
T PP	11.4	6.2	12.8	15.9
L1	742	1045	1348	1664
L2	525	810	977	1177
A	355	395	482	545
B	250	260	310	320
C	160	160	200	200
D	160	160	200	200
S	138	173	215	273

Vistus® complete system without separator

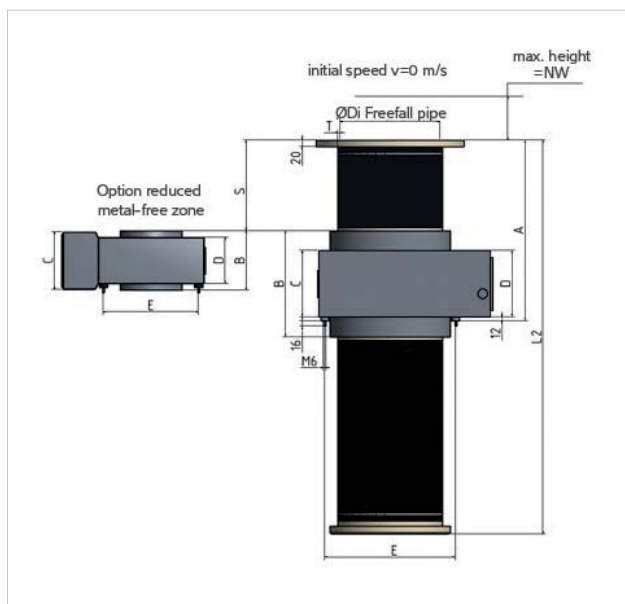

Coil and freefall pipe version

Metal detector opening	8.4	12	17.2	21.6	26.9	34.1
NW	80	100	150	200	250	300
Di PP	55.8	96.8	152.2	190.2	237.8	299.6
Di ESD	55.8	97.4	141.8	177.2	221.6	279.2
Di ceramic	--	80	100	150	200	250
T PP	3.6	6.6	3.9	4.9	6.1	7.7
T ESD	3.6	6.3	9.1	11.4	14.2	17.9
T ceramic	--	10	10	10	10	10
L2	364	432	525	606	740	866
A	274	308	355	395	482	545
B	230	240	250	260	310	320
C	160	160	160	160	200	200
D	160	160	160	160	200	200
D1	125	180	240	295	350	400
D2	18	18	22	22	22	22
D3	165	220	285	340	395	445
E	160	160	256	256	395	395
S	67	96	138	173	215	273

Coil and freefall pipe version with shielding and/or air cooling

Metal detector opening	12	17.2	21.6	26.9	34.1	34.1
NW	80	100	150	200	250	300
Di PP	55.8	96.8	152.2	190.2	237.8	299.6
Di ceramic	80	100	150	200	250	300
T PP	3.6	6.6	3.9	4.9	6.1	7.7
T ceramic	10	10	10	10	10	10
L2	432	525	606	740	866	866
A	308	355	395	482	545	545
B	240	250	260	310	320	320
C	160	160	160	160	200	200
D	160	160	160	160	200	200
D1	125	180	240	295	350	400
D2	18	18	22	22	22	22
D3	165	220	285	340	395	445
E	160	160	256	256	395	395
S	96	138	173	215	273	273

Coil and freefall pipe version with reduced metal-free zone

Metal detector opening	8.4	12	17.2	21.6	26.9	34.1
NW	80	100	150	200	250	300
Di PP	55.8	96.8	152.2	190.2	237.8	299.6
Di ESD	55.8	97.4	141.8	177.2	221.6	279.2
Di ceramic	--	80	100	150	200	250
T PP	3.6	6.6	3.9	4.9	6.1	7.7
T ESD	3.6	6.3	9.1	11.4	14.2	17.9
T ceramic	--	10	10	10	10	10
L2	196	279	400	501	624	791
A	144	199	281	349	432	544
B	88	125	180	225	280	355
C	68	96	138	173	215	273
D	173	173	173	173	215	215
D1	125	180	240	295	350	400
D2	18	18	22	22	22	22
D3	165	220	285	340	395	445
E	160	160	256	256	395	395
S	54	77	110	138	172	218

True In-Process Validation

Scale drawing

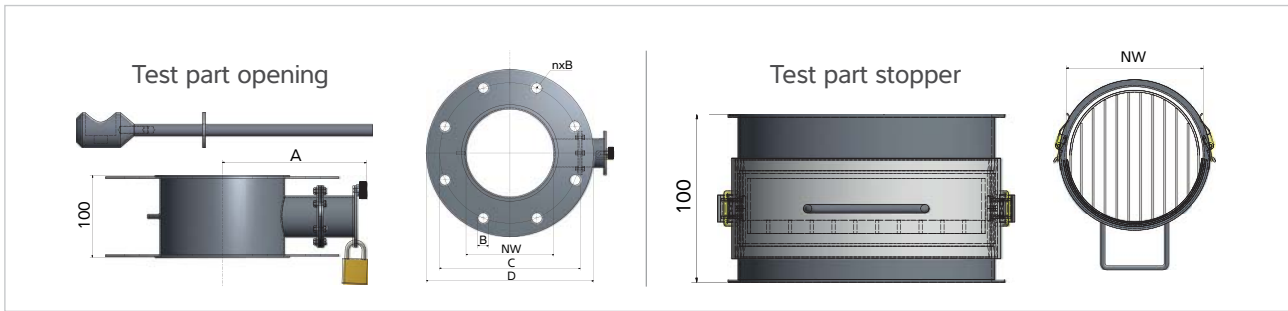

NW	A	B	C	D	n
100	139	18	180	220	8
150	166	18	240	285	8
200	192.5	22	295	340	8
250	218	22	350	395	12
300	243.5	22	400	445	12

The test part opening and test part stopper can be closed. Go to the last page for more about our test part range and to find suitable test parts for you.

Air pressure monitoring and compressed air conditioning



When you purchase a freetail system Vistus® with separator, 5 L/2 L air cells, air pressure monitoring and a pressure relief valve are all included (5 L from nominal width 250 upwards, if not 2 L). The pressure relief valve comes with a sound absorber. The components, made by the market leader, are high-quality and long-lasting.

Hole size, 2 L air cell

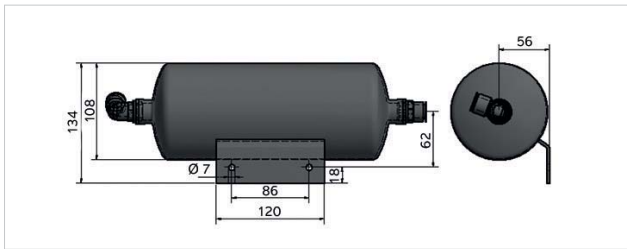

Hole size, 5 L air cell

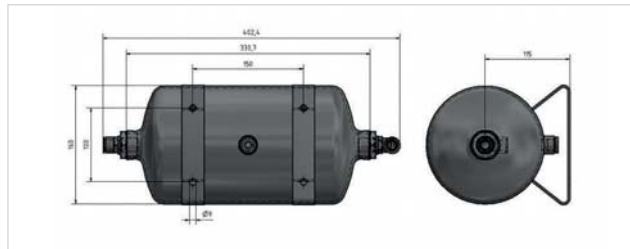

Standard maintenance unit

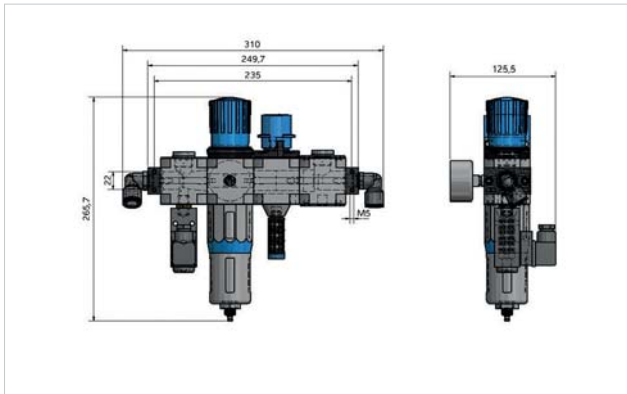

Category 3 maintenance unit

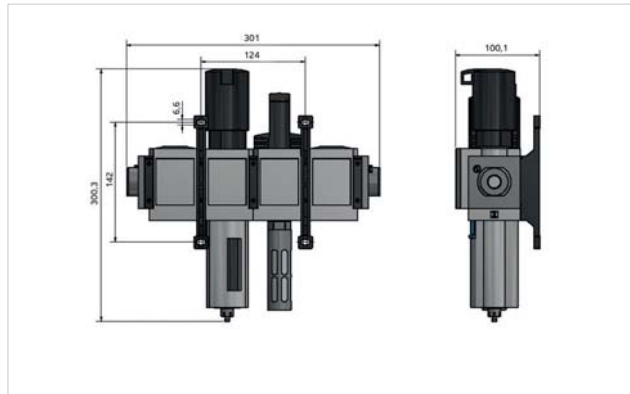

An optional hygienic protective housing is available for the compressed air conditioning.

Inlet and outlet flanges on the conveyor tube

Inlet flange F1

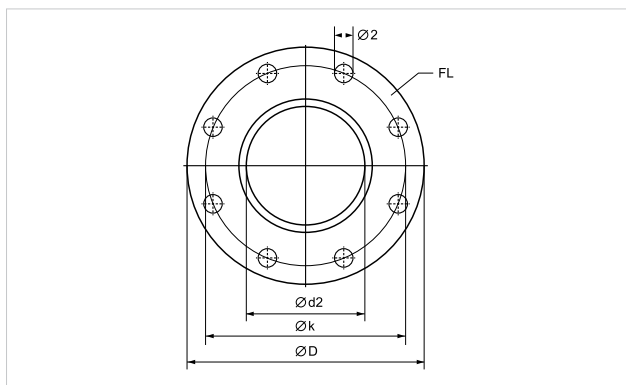

Metal detector opening	8.4	12	17.2	21.6	26.9	34.1
-FL/-ST/-EC	8	10	15	20	25	30
NW	80	100	150	200	250	300
D	200	220	285	340	395	445
k	160	180	240	295	350	400
d2	18	18	22	22	22	22
E	8	8	8	8	12	12

DIN- or ANSI-compliant outlet flange F2

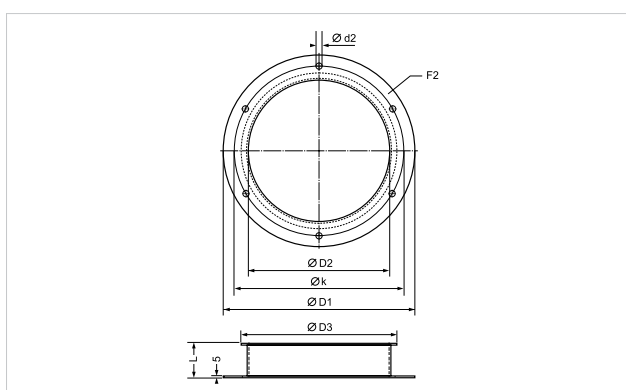

Metal detector opening	8.4	12	17.2	21.6	26.9	34.1
-FL/-ST/-EC	8	10	15	20	25	30
NW	80	100	150	200	250	300
D	123	150	202	250	300	355
D2	78	99	149	199	249	299
D3	95	115	165	215	265	315
k	108	130	180	230	280	330
d2	6	6	6	6	6	8
E	8	8	8	8	12	12
L	35	28	36	37	48	50
S	1	2	2	2	2	2

Optional BFM flange

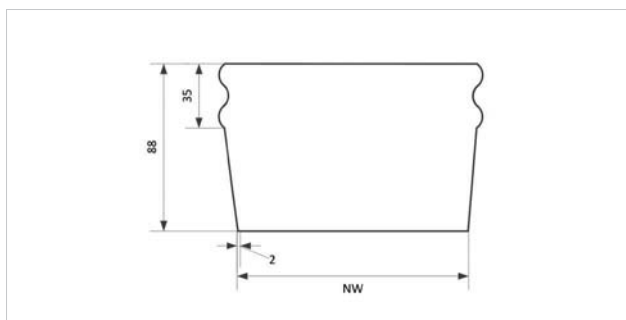

-FL/-ST/-EC	10	15	20	25	30
NW	97	147	200	250	300

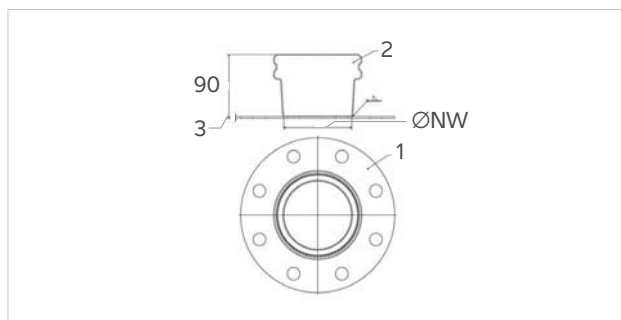

-FL/-ST/-EC	10	15	20	25	30
NW	100	150	200	250	300

Collection container

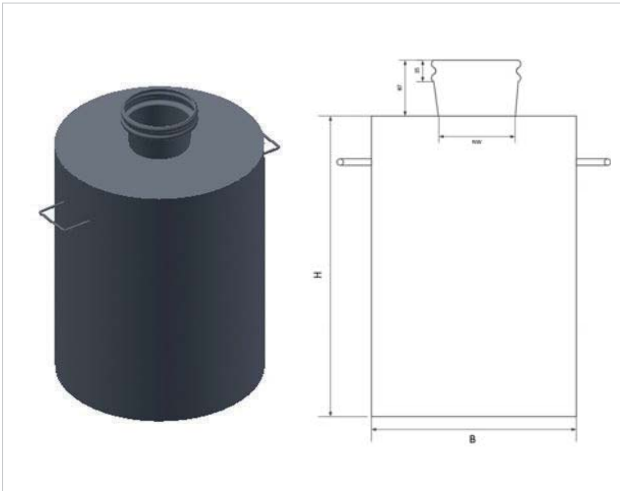

Volume	NW	H	B
50 L	97	555	340
50 L	146	555	340
50 L	200	555	340
50 L	250	555	340
50 L	300	55	340
75 L	97	620	400
75 L	146	620	400
75 L	200	620	400
75 L	250	620	400
75 L	300	620	400
100 L	97	670	450
100 L	146	670	450
100 L	200	670	450
100 L	250	670	450
100 L	300	670	450

All run-off containers come with a BFM connection flange.

Flex pipe



Optional 'flex piping', sold by the metre, is available to purchase to connect frefall systems with upstream or downstream systems or to ensure dust-free connection of the run-off container. Ideally, this will be combined with the BFM connection flange. It consists of polyether-based polyurethane and meets food safety requirements set in EU regulations 1935/2004, 10/2011, 2023-2003 and FDA CFR21 177.2600/1680; material thickness 0.9/0.35 mm, -25 -110 / 80 °C temperature resistance.

Hygienic cover for pneumatic assembly

Integrating the pneumatic assembly and the compressed air conditioning unit into a hygienic stainless steel cabinet protects them against contamination. This in turn reduces the amount of cleaning work required and also ensures correct user intervention.

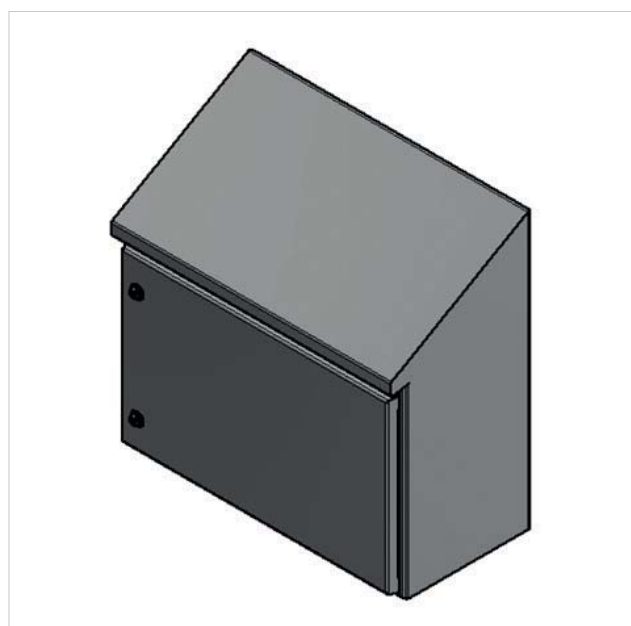
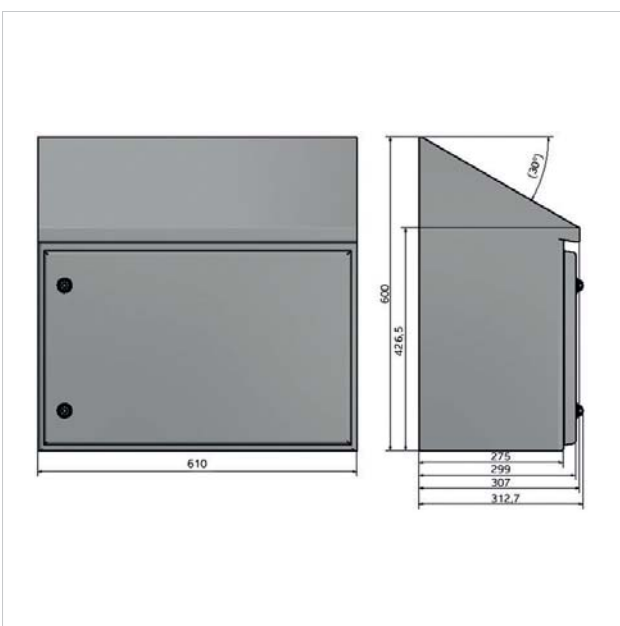

Standard frame for upright assembly

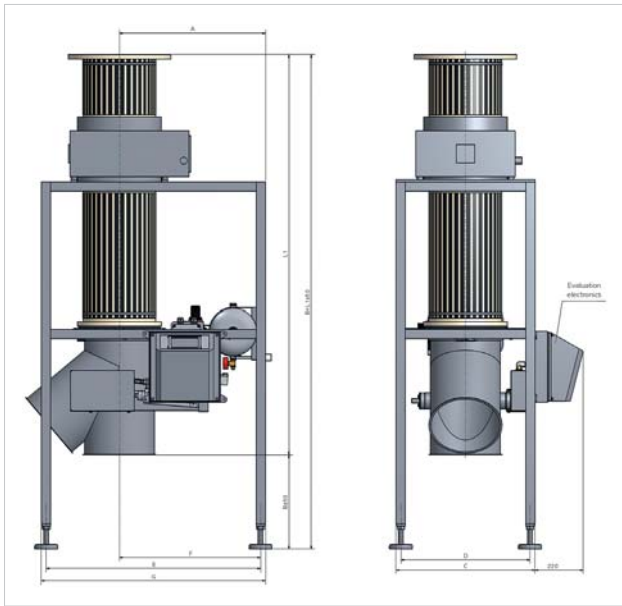

Version with frame

Metal detector opening	8.4	12	17.2	21.6	26.9	34.1
-FL/ -ST/ -EC	8	10	15	20	25	30
NW	80	100	150	200	250	300
L1	version-dependent; see tables 1 and 2					
A	564	564	539	589	634	634
B	340	330	390	400	420	410
C	478	478	478	478	603	603
D	435	435	435	435	560	560
E	710	710	710	760	930	930
F	542.5	542.5	517.5	567.5	612.5	612.5
G	753	753	753	803	973	973

Should your application require a customised solution, we can provide professional implementation via our Engineering Support team.

Technical data for Vistus® TCU with separator FL

Supply pressure	4.0 bar to 10.0 bar overpressure	
Operating medium	Compressed air as per ISO 8573-1:2010 [7:4:4]	
Operating pressure	Min. 4.5 bar to max. 6.0 bar overpressure	
Air consumption	- Up to ID 200 - ID 250 and ID 300 Approx. 0.3 litres per separation Approx. 0.5 litres per separation	
Solenoid valve for compressed air connection	G 1/4" internal thread for plastic tube 10 mm, connection venting aperture M5	
Compressed air tank	G 1/2" with connection for plastic tube 14 mm (included in purchase price when purchasing complete system with separator)	
Pressure relief valve	Provided free of charge to protect your system	
Recommended on-site compressed air quality	Particulate matter class 4 Water class 2 Oil class 2	(Quality classes as per PNEUROP recommendation 6611)
Drop height	Max. distance to inlet flange for initial speed $v = 0$ m/s depending on the respective nominal width (NW) in mm (greater drop heights require larger installation dimensions)	
Solenoid valve	5/2-way valve monostable	
- Supply voltage	Choice of 230 V _{AC} or 115 V _{AC} 50/60 Hz, or 24 V _{DC} standard or 48 V _{DC} (please specify any deviations from the standard (24 V DC) upon order)	
- Activation	Via 'Metal' relay on evaluation electronics	
Protection class	IP65	
Supply voltage	90 V to 260 V	
Explosion protection	Version approved for II 1/3D c T120° 0 °C ≤ Ta ≤ +40 °C	
User interface	145 mm (5.7") touchscreen Password-protected, user-specific access to dialogues that are organised and adapted by functional areas Automatic teach-in function	
Relay outputs	Total of 4 relays ---> relays 1, 3 and 4 freely programmable Relay 2 'Error': fixed assignment	
Relative air humidity	Operation: < 58 % at +55 °C / Storage: < 30 % at +70 °C, 0 % to 90 % condensation-free	
Ambient temperature	Operation: -10 °C to +55 °C	
Product temperature	-30 to +55 °C, but product temperatures of up to +150 °C are possible if needed, if air cooling is connected, subject to the product characteristics	

Options

Various additional options

- End position monitoring
- Signal lights & signal horn
- Fill level monitoring
- Fingerprint sensor



Scope of delivery: 4 x test balls, or test rods; other test part options are available

Interfaces

- RS 232, RS 422
- USB printing
- TCP-IP XML server/client
- Remote control
- Profibus
- SPC@Enterprise

The technical data given serves as a product description only and should not be understood as guaranteed properties in the legal sense.

Specifications subject to change without notice.