

A
B
C
D

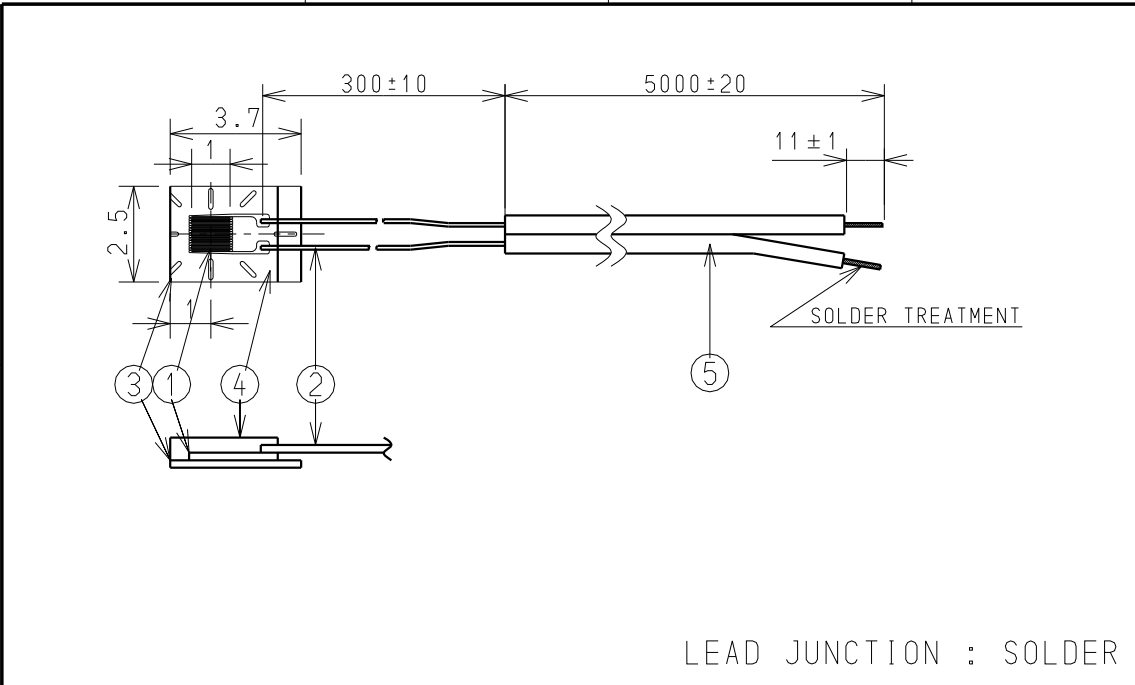

PARTS LIST

ITEMS	DESCRIPTION	REF. DATA	REQ.
1	GRID	COPPER NICKEL ALLOY (T11)	1
2	GAGE LEAD	POLYURETHANE WIRE $\phi 0.14 \times 300\text{mm}$	2
3	BASE	POLYIMIDE	1
4	COVER	POLYIMIDE	1
5	LEAD WIRE	7/0.12 2C DIA $\phi 1\text{mm}$	1

SPECIFICATION

RESISTANCE : $119.7\Omega \pm 0.3\Omega$
 : $120.3\Omega \pm 0.3\Omega$

GAGE LENGTH : 1mm

GAGE FACTOR : 1.8~2.1

TEMPERATURE RANGE : -50°C to 70°C



					ミネベア株式会社 MINEBEA CO.,LTD. 計測機器事業部		単位 UNIT mm 尺度 SCALE FREE	材質 MATERIAL - 表面粗さ SURF.ROUGH. - 熱処理 HEAT TREAT. - 表面処理 FINISH -	作成日 DATE 2013.01.29 品名 DESCRIPTION J-1-12L30W5MS 品番 PART NO.(MODEL NO.) - 図番 DRAWING NO. G900462-1	葉番 SHEET - 改訂 REV. -	
					APPROVED	CHECKED	DRAWN				
					D. Inomori	E. MISAIZU	E. MISAIZU				
符号 MARK	日付 DATE	ECN NO.	担当 ENGINEER	承認 APPROVED			公差 TOL				
							寸法 L 公差 $<L \leq 4$ ± 0.1 $4 < L \leq 16$ ± 0.2 $16 < L \leq 63$ ± 0.3 $63 < L \leq 250$ ± 0.5 $250 < L \leq 1000$ ± 0.8 角度 DEG ± 0.5				