

PARTS LIST

ITEMS	DESCRIPTION	REF. DATA	REQ.
1	FOIL	NICKEL CHROMIUM ALLOY	3
2	GAGE LEAD	POLYURETHANE $\phi 0.1 \times 300\text{mm}$	6
3	BASE	EPOXY	3
4	COVER	POLYIMIDE	1
5	LEAD WIRE	7/0.12 2C DIA $\phi 1\text{mm}$	3

SPECIFICATIONS

RESISTANCE	: $120.0\Omega \pm 2.0\Omega$
GAGE LENGTH	: 0.5mm
GAGE FACTOR	: 1.8~2.1
TEMPERATURE RANGE	: -50°C to 70°C

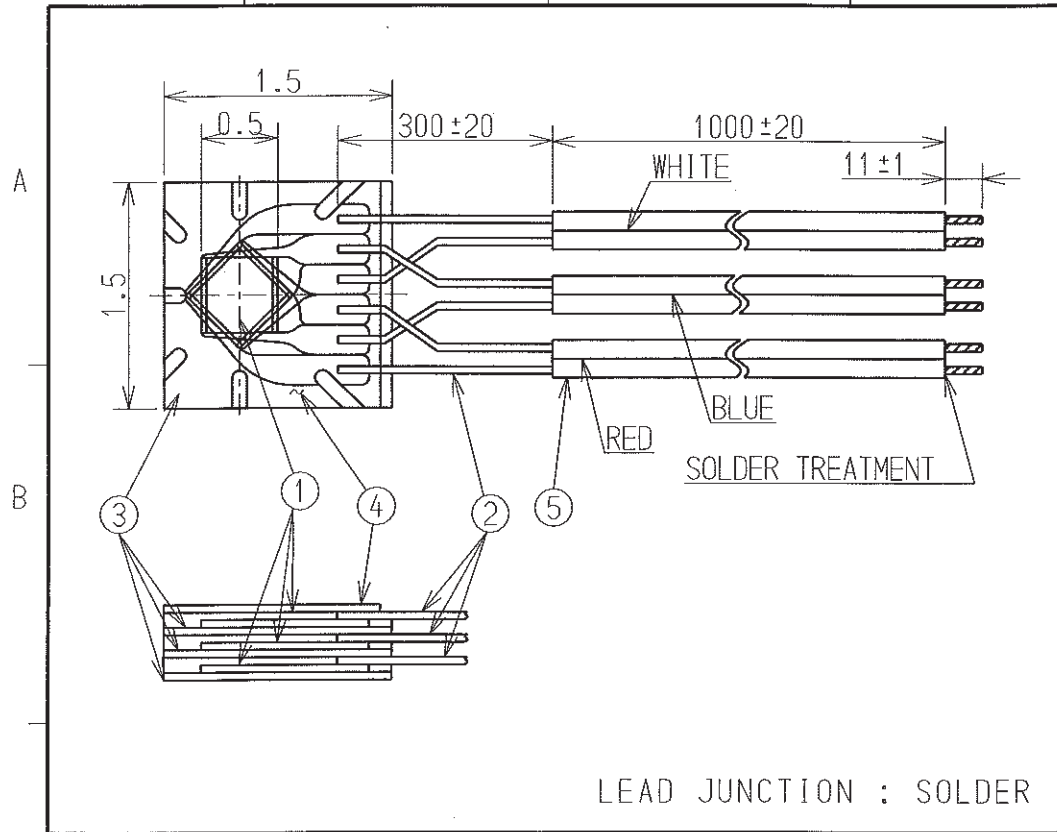

公布	
K	
S	
T	
F	

					ミネベア株式会社 MINEBEA CO.,LTD. 計測機器事業部		単位 UNIT mm 尺度 SCALE FREE	材質 MATERIAL - 表面粗さ SURF.ROUGH. - 熱処理 HEAT TREAT. - 表面処理 FINISH -	作成日 DATE 2014/02/19 品名 DESCRIPTION YFR-0512L30W1MS 品番 PART NO.(MODEL NO.) - 図番 DRAWING NO. G900499-1	葉番 SHEET / 改訂 REV. -
					APPROVED	CHECKED	DRAWN			
					D. Inomori	E. MISAIZU	S. YAMAMOTO			
符号 MARK	日付 DATE	ECN NO.	担当 ENGINEER	承認 APPROVED						
-	2014/02/19	NEW	YAMAMOTO	D. Ina						